

Portable Compressors

## Mobilair™ M14



### Compact, lightweight unit

The Mobilair™ M14 is a rugged and dependable unit that is perfect for a variety of applications. Light construction, carpentry and monument engraving are just a few areas where the M14 is ideal. With a folding handle, oversized pneumatic tires and compact size, this unit can be used on virtually any job site.

The standard inlet filter is rated at 4 microns at 99.9% efficiency and allows the unit to operate in most any construction environment. The M14 is equipped

with modulation control which allows the compressor to match the load demand. This feature is reinforced by the safety system, which includes low oil pressure and high discharge air temperature shut-downs that protect the unit.

This unit is easy to use with an electric starting system and has a clearly visible control panel.

The M14 is enclosed in durable, powder-coated sheet metal, which protects the compressor as well as the operator.

**Capacity:** 50 cfm  
(operates up to 60 lb. paving breaker)

**Pressure:** 100 psig

### Standard Features:

- Single stage, oil injected rotary screw airend with power-saving proprietary Sigma Profile
- Briggs & Stratton, 4-cycle, V-twin, industrial duty engine
- Engine rated 18 hp @ 3000 rpm
- Uses lead-free gasoline
- Compressor and engine are disengaged for easy starting, even in cold conditions
- Electric start
- Belt-driven with a three-groove power band
- Control panel displays pressure, discharge air, temperature, and hour meter
- Protective sheet metal enclosure with durable powder coated finish
- Vibration isolation for smooth operation
- 4 micron air intake filter

## Specifications

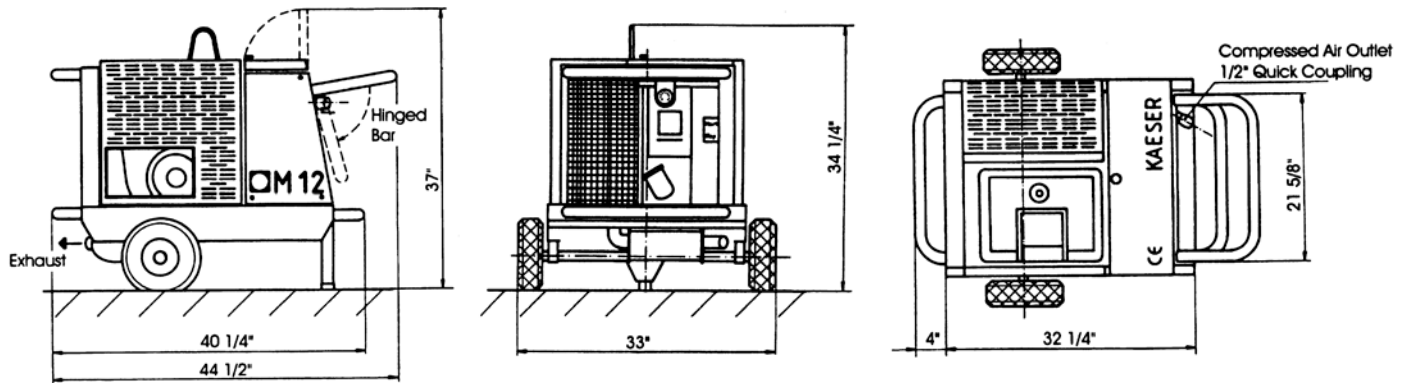

Model	Dimensions L x W x H (in.)	Weight (lb.)	BHP	cfm @ 100 psig
M14	40-1/4 x 33 x 34-1/4	360	13.4	50

### MobilairTools™

The M14 can be used to operate a wide variety of air tools. See Kaeser's MobilairTools™ Brochure for specifications.



Specifications are subject to change without notice.

# KAESER COMPRESSORS

**Built for a lifetime.™**

Corporate Headquarters:  
P.O. Box 946  
Fredericksburg, Virginia 22404  
Phone 540-898-5500  
Fax 540-898-5520  
www.kaeser.com



### The Air Systems Specialist

With over 85 years of experience, Kaeser is the air systems specialist. Our extensive 100,000 square foot facility allows us to provide unequalled product availability. With service centers nationwide and our 24-hour emergency parts guarantee, Kaeser customers can rely on the best after-sales support in the industry. Kaeser stands committed on providing the highest quality air system for your specific compressed air needs.